

JET

JPM-13CSX

**Комбинированный
рейсмусово-фрезерный
станок**

708524T...380/50/3

Список деталей

WMH Tool Group AG

Bahnstrasse 24,
CH - 8603 Schwerzenbach
www.wmhtoolgroup.ch
info@wmhtoolgroup.ch
Tel +41 (0)44 806 47 48
Fax +41 (0) 44 806 47 58

P-708254T...01/01



Монтажная схема: стол и основание в сборе

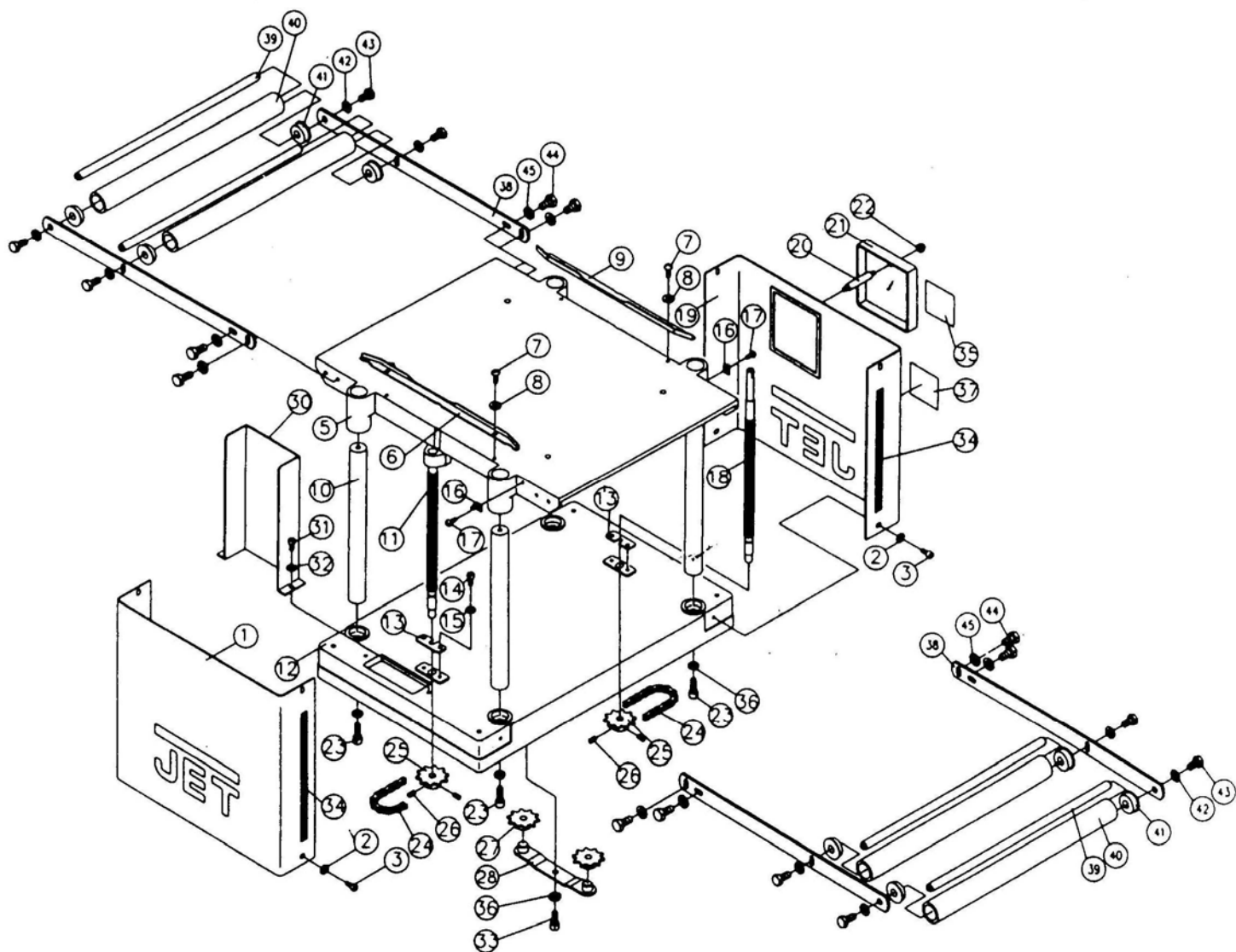

Список деталей: стол и основание в сборе

№	№ детали	обозначение	размер	кол-во
1	MHA-B01W	Cover (left)		1
2	TS-0680021	Flat Washer	1/4	8
3	TS-1503011	Hex Socket Cap Screw	M6x8	8
4	MGA-B05	Scale (inch)		1
5	MHA-B02	Middle Table (serial #6082715 and lower)		1
	MHA-B02AW	Middle Table (serial #6082716 and higher)		1
6	MGA-B29	Guide (left)		1
7	TS-1534031	Pan Head Machine Screw	M6x10	4
8	TS-1551041	Lock Washer	M6	4
9	MGA-B15	Guide (right)		1
10	MHA-B03	Column		4
11	MHA-B04	Leadscrew (left - serial # 6082715 and lower)		1
	MHA-B04A	Leadscrew (left-serial #6082716 and higher)		1
12	MHA-B05W	Base		1
13	MGA-B09	Anchor Plate		2
14	TS-1503031	Hex Socket Cap Screw	M6x12	4
15	TS-1551041	Lock Washer	M6	4
16	MHA-B20	Pointer		2
17	TS-1532022	Pan Head Machine Screw	M4x8	2
18	MHA-B06	Leadscrew (right - serial # 6082715 and lower)		1
	MHA-B06A	Leadscrew (right-serial #6082716 and higher)		1
19	MHA-B07	Cover (right-serial #810xxxx and lower)		1
	MHA-B07UW	Cover (right-serial #811xxxx and higher)		1
21	MHA-B09	Gear Box Cover (serial #810xxxx and lower)		1
	MHA-B09U	Gear Box Cover (serial #811xxxx and higher)		1
22	5BB-B07	Hex Nut		1
23	TS-1504051	Hex Socket Cap Screw	M8x25	4
24	5GF-B07	Chain		1
25	PGE-B14	Sprocket		2
26	TS-1523011	Set Screw	M6x6	4
27	PGE-B12	Sprocket		2
28	PGE-B10	Sprocket Idler/Bracket Bushing		1
29	PGE-B11	Bracket Bushing *RE:PGE-B10		2
30	MHA-B10W	Pulley Cover		1
31	TS-1503021	Hex Socket Cap Screw	M6x10	2
32	TS-0680021	Flat Washer	1/4	2
33	TS-1504051	Hex Socket Cap Screw	M8x20	1
34	MGA-B04	Scale (metric)		1
35	MHA-B11	Speed Label (serial #81 0xxxx and lower)		1
	MHA-B11U	Speed Label (serial #811xxxx and higher)		1
36	TS-1551061	Lock Washer	M8	5
37	MHA-C18	Identification Label		1
38	MHD-Y01A	Roller Frame		4
39	MHA-Y02A	Roller Shaft		4
40	MHA-Y02C	Roller		4
41	PJ020804	Bushing		8
42	TS-1550041	Flat Washer	M6	8
43	TS-1482021	Hex Cap Bolt	M6x12	8
44	TS-1490011	Hex Cap Bolt*	M8x12	8
45	TS-1550061	Flat Washer *	M8	8

Монтажная схема: строгальная голова и вал в сборе

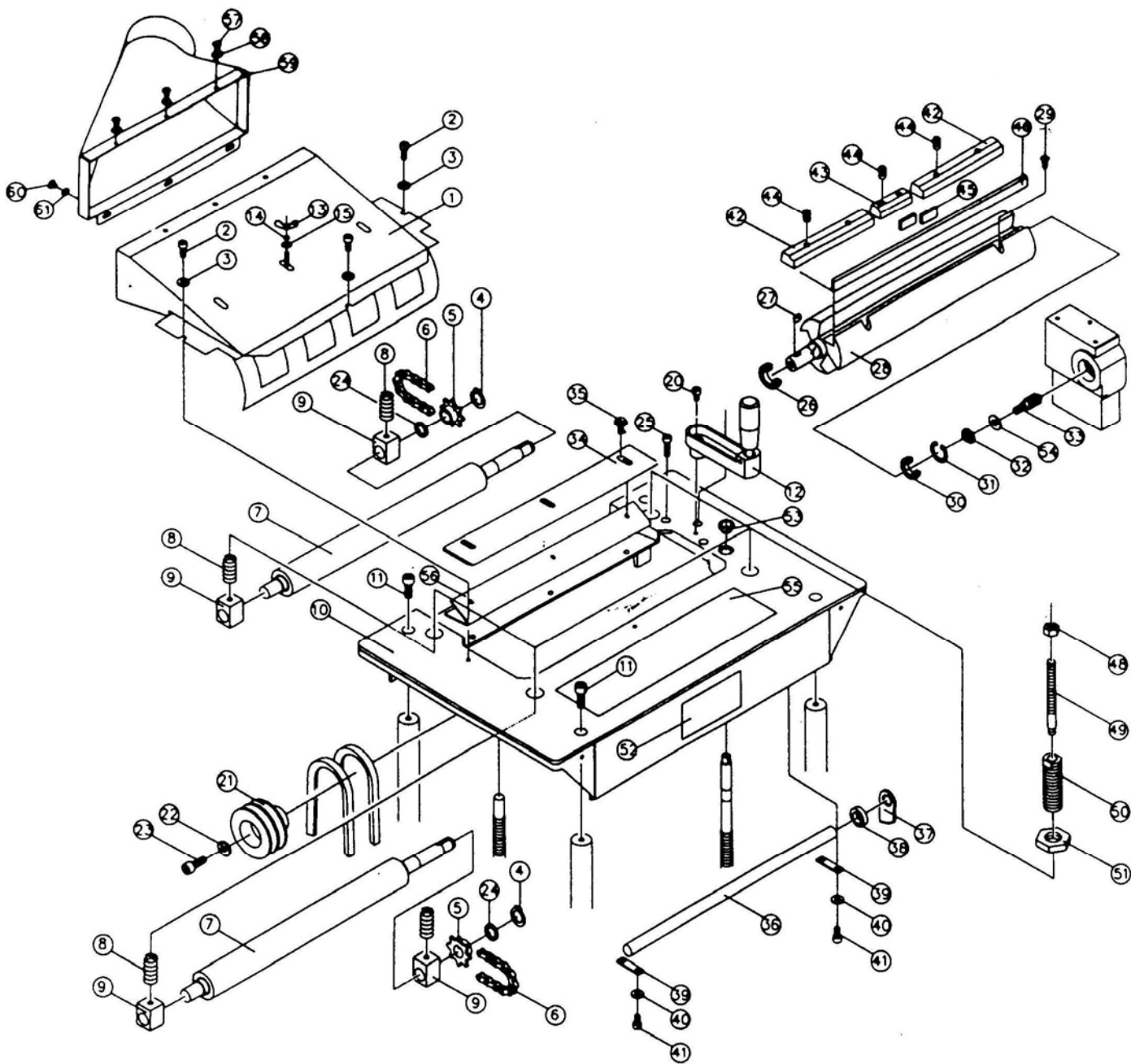

Список деталей: строгальная голова и вал в сборе

№	№ детали	обозначение	размер	кол-во
	MHA-CW	Dust Hood Assembly CP		1
1	MHA-C01AW	Dust Hood		1
2	TS-1503011	Hex Socket Cap Screw	M6x8	3
3	TS-0680021	Flat Washer	1/4	3
4	5FA-A10	C-Ring	STW15	2
5	PGA-C17	Sprocket		2
6	5GF-B08	Chain		2
7	MHA-C02	Feed Roller		2
8	PGA-C09	Spring		4
9	MGA-C09	Bushing		4
10	MHA-C03W	Head Body		1
11	TS-1504041	Hex Socket Cap Screw	M8x20	4
12	PGE-B19A	Handle Assembly		1
13	TS-1543021	Wing Nut		3
14	PGE-B19B	Bushing		1
15	PGE-B19C	Stud		1
20	TS-1503021	Hex Socket Cap Screw *	M6x10	1
21	MHA-C05	Spindle Pulley		1
22	TS-0680021	Flat Washer	1/4	1
23	TS-1503051	Hex Socket Cap Screw	M6x20	1
24	MHA-C06	Spacer		2
25	TS-1503041	Hex Socket Cap Screw	M6x16	3
26	BB-6203ZZ	Ball Bearing		1
27	5FK-C06	Key	5x5x15	1
28	MHA-C07	Cutterhead		1
29	TS-1513021	Flat Head Screw	M5x12	6
30	BB-6202ZZ	Ball Bearing		1
31	5BA-A28	C-Ring	RTW35	1
32	MHA-C08	Bushing		1
33	MHA-C09	Gear		1
34	MHA-C10	Chip Deflector		1
35	5AK-E128	Screw	M6x12	3
36	MHA-C11	Anti-Kickback Shaft		1
37	MGA-C30	Anti-Kickback Finger		36
38	MGA-C34	Anti-Kickback Collar		37
39	MGA-C31	Bracket		2
40	TS-1551031	Lock Washer	M5	4
41	TS-1502011	Hex Socket Cap Screw	M5x8	4
42	MHA-C12	Lock Bar (long)		6
43	MGA-C22	Lock Bar (short)		3
44	TS-1524031	Set Screw	M8x12	18
45	MGA-C23	Lock Bar Spacer		6
46	MHA-C13	Knife		3
48	TS-1540071	Hex Nut	M10x1.5	4
49	MGA-C07	Adjustment Screw		4
50	MGA-C05	Adjustment Screw		4
51	MGA-C06	Nut		4
52	MHA-C19	Warning Label (long)		1
53	PGE-B13	Bushing		1
54	MHA-C20	Washer		1
55	PJE-C03	Warning Label (small)		1
56	MHA-C22W	Plate		1
57	TS-1533031	Screw*	M5x10	3
58	TS-1550031	Flat Washer *	M5	3
59	MHA-Y01AW	Dust Chute		1
60	HS040703	Screw*	M6x8	3
61	TS-1550041	Flat Washer*	M6	3

Монтажная схема: коробка передач в сборе

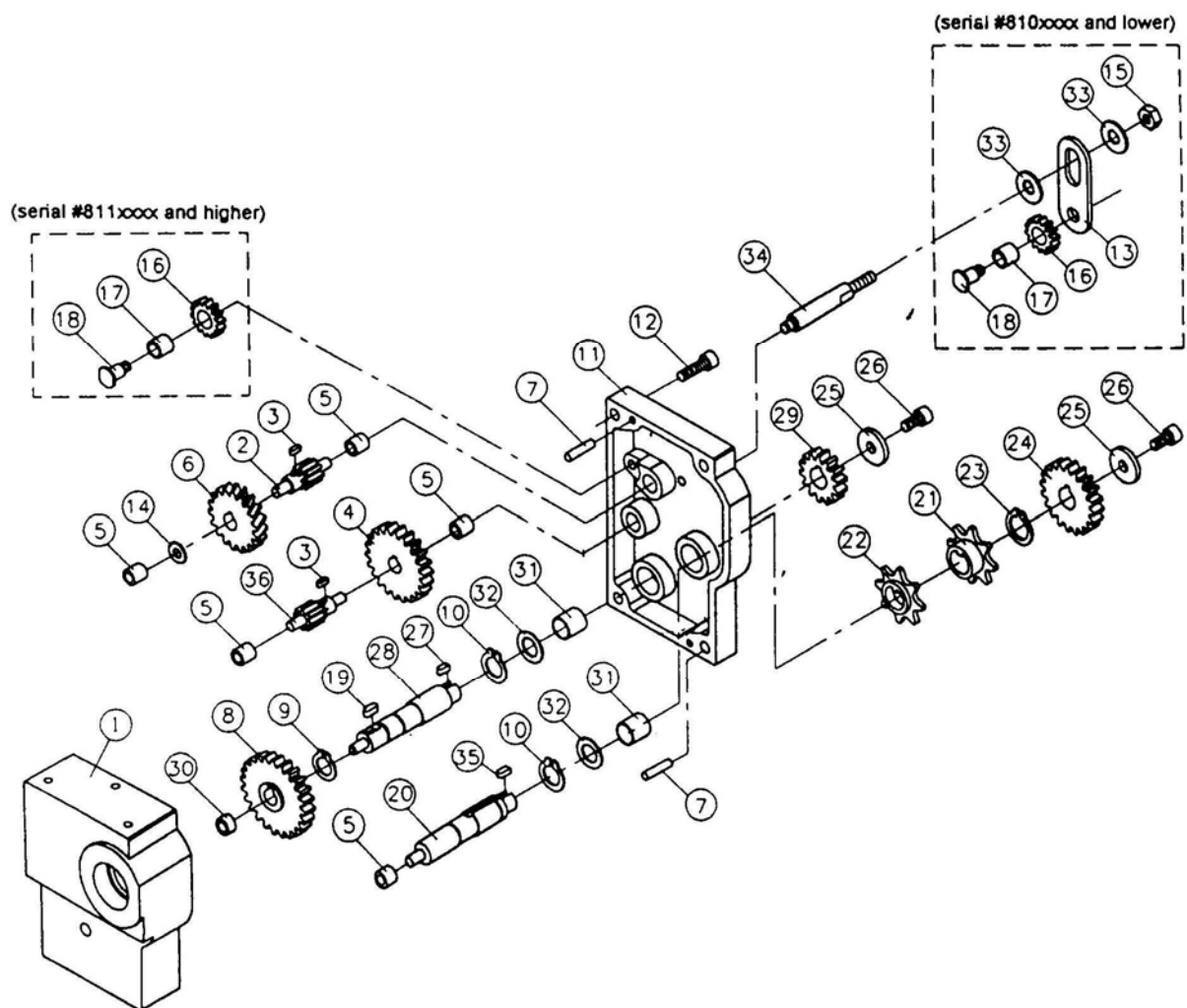

Список деталей: коробка передач в сборе

№	№ детали	обозначение	размер	кол-во
	MHA-G.....	Gearbox, #'s 1-33,35 (serial #810xxxx and lower)		1
	MHA-GUW	#'s 1-12,14,16-32,35-36 (ser. #811xxxx and higher)		1
1	MHA-G01	Gearbox Body (serial #81 0xxxx and lower)		1
	MHA-G01UW.....	Gearbox Body (serial #811xxxx and higher)		1
2	MHA-G02	Gear Shaft (serial #81 0xxxx and lower)	10T	2
	MHA-G02	(pear Shaft (serial #811xxxx and higher)	10T	1
3	FK-A03	Key	3x3x8	2
4	MHA-G03	Gear (serial #810xxxx and lower)	46T	1
	MHA-G03U	Gear (serial #811 xxxx and higher)	44T	1
5	PGA-M15.....	Bushing		5
6	MHA-G04	Gear, (serial #810xxxx and lower)	38T	1
	MHA-G04U	Gear (serial #811 xxxx and higher)	43T	1
7	MGA-C28	Pin	4x16	2
8	MHA-G05	Gear (serial #810xxxx and lower)	51T	1
	MHA-G05U	Gear (serial #811xxxx and higher)	47T	1
9	5FA-A07.....	C-Ring	STW12	1
10	5FA-A07.....	C-Ring	STW12	2
11	MHA-G06	Gearbox Cover (serial #607xxxx and lower)		1
	MHA-G06N	Gearbox Cover (serial #608xxxx to 810xxxx)		1
	MHA-G06UW.....	Gearbox Cover (serial #841xxxx and higher)		1
12	TS-1503051	Hex Socket Cap Screw	M6x20	4
13	MHA-G07	Bracket (serial #607xxxx and lower)	R.H	1
	MHA-G07N	Bracket (serial #608xxxx to 81 0xxxx)	L.H	1
14	TS-0680021	Flat Washer (serial #810xxxx and lower)	1/4	2
	TS-0680021	Flat Washer (serial #811 xxxx and higher)	1/4	1
15	TS-1540041	Hex Nut (serial #81 0xxxx and lower)	M6x1.0	1
16	MHA-G08	Gear (serial #607xxxx and lower)	24T	1
	MHA-G08N	Gear (serial #608xxxx to 81 0xxxx)	28T	1
	MHA-G08U	Gear (serial #811xxxx and higher)	22T	1
17	PGA-M12.....	Bushing		1
18	MHA-G09	Stud Bolt (serial #607xxxx and lower)		1
	MHA-G09N	Stud Bolt (serial #608xxxx and'higher)		1
19	MHA-G18	Key	5x5x9	1
20	MHA-G10	Shaft (serial #607xxxx and lower)		1
	MHA-G10N	Shaft (serial #608xxxx and higher)		1
21	PGA-C17.....	Sprocket		1
22	MGA-C32	Sprocket		1
23	5FA-A10.....	C-Ring	STW15	1
24	MHA-G 11	Gear (serial #81 0xxxx and lower)	43T	1
	MHA-G11U	Gear (serial #811xxxx and higher)	40T	1
25	5EB-A08	Washer		2
26	TS-1503031	Hex Socket Cap Screw	M6x12	2
27	5FK-B02	Key	4x4x7	1
28	MHA-G12	Shaft (serial #607xxxx and lower)		1
	MHA-G12N	Shaft (serial #608xxxx to 81 0xxxx)		1
	MHA-G12U	Shaft (serial #811 xxxx and higher)		1
29	MHA-G13	Gear (serial #810xxxx a*nd lower)	31T	1
	MHA-G13U	Gear (serial #811xxxx and higher)	29T	1
30	MHA-G14	Bushing (serial #81 0xxxx and lower)	I.D. 6	1
	MHA-G14U	Bushing (serial #811 xxxx and higher)	I.D. 10	1
31	MHA-G15	Bushing (serial #607xxxx and lower)		2
	MHA-G15N	Bushing (serial #608xxxx and higher)		2
32	MHA-G16	Washer		2
33	MHA-G17	Washer (serial #810xxxx and lower)		2
34	MHA-B08	Stud		1
35	5FK-B05	Key	4x4x12	1
36	MHA-G19	Gear Shaft (serial #811 xxxx and higher)	10T	1

Монтажная схема: станина и двигатель в сборе

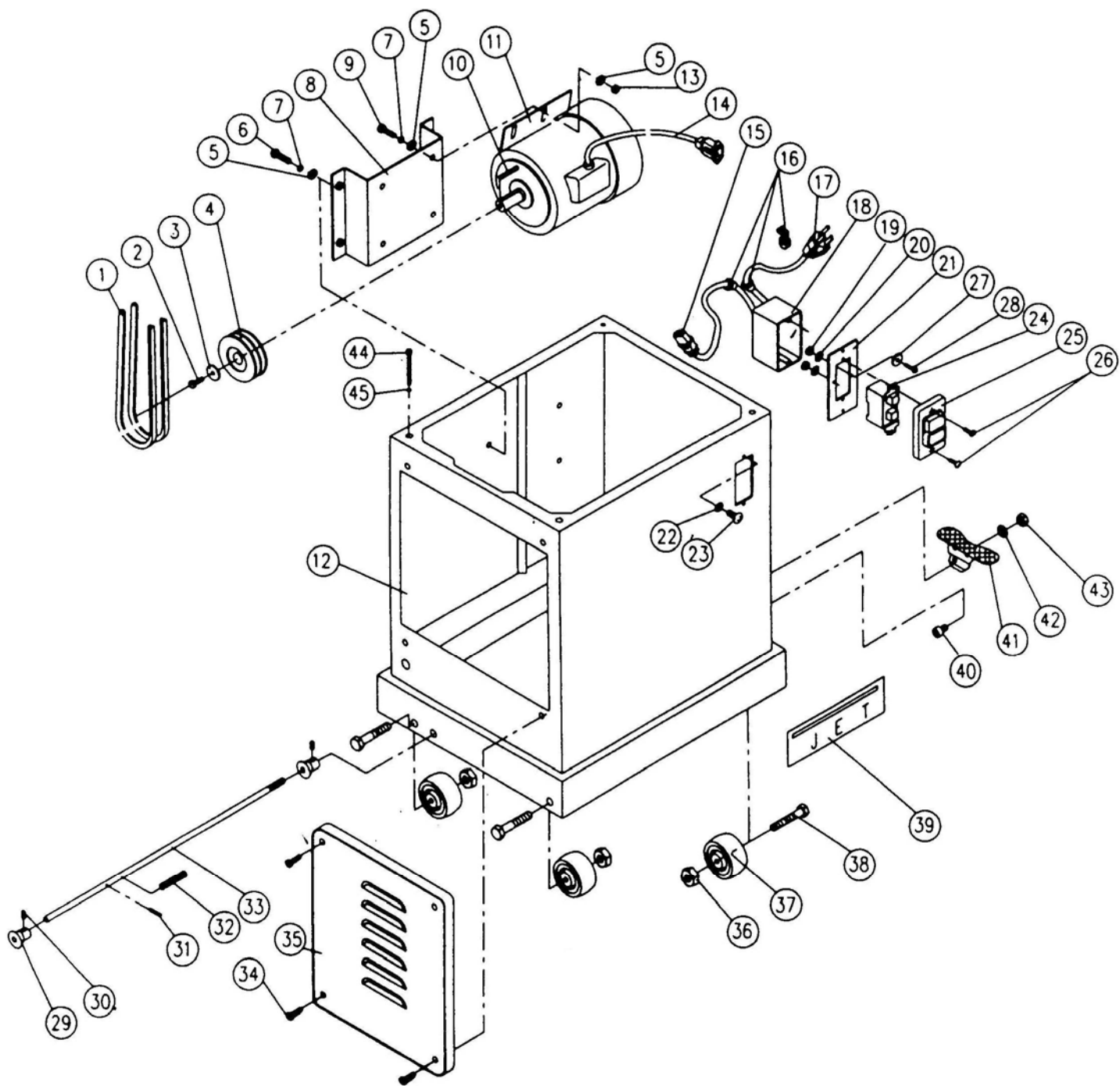

Список деталей: станина и двигатель в сборе

№	№ детали	обозначение	размер	кол-во
1	VB-M45	V-Belt		2
2	TS-0051011	Hex Cap Bolt	5/16-18NCx1/2	1
3	PJA-C03	Washer		1
4	MHA-S01	Motor Pulley		1
5	TS-1550061	Flat Washer	M8	12
6	TS-2288202	Round Cap Hex Socket Slot Screw	M8x1.25x20	4
7	TS-1551061	Lock Washer	M8	8
8	MHD-S02	Motor Bracket		1
9	TS-1490031	Hex Cap Bolt	M8x1.25x20	4
10	5FK-C13A	Key	5x5x30	1
11	MHA-S02AW	Motor	1 1/2 HP 115/230V	1
	MHA-S02W	Motor Assy. (inc. 10, 11, 14)		1
12	MHD-S01	Stand		1
13	TS-1540061	Hex Nut	M8x1.25	4
14	MHA-S02B	Motor Cord	14AWG	1
15	MHA-S14	Switch Cord	14AWG	1
16	5MA-I04	Strain Relief Bushing		3
17	MHA-S16	Power Cord	14AWG	1
18	JEA-S14	Switch Box		1
19	TS-1540021	Hex Nut	M4	2
20	5EB-E05	Star Washer	M5	2
21	JE090702	Plate		1
22	5EB-A04	Washer	M5	2
23	5CD-C06B	Screw	3/16-24NCx1/2	2
24	JE011302	Switch		1
25	JI-X01	Switch Cover		1
26	5AL-C10A	Pan Head Machine Screw	M4x25	2
27	TS-1550021	Washer		2
28	TS-2284301	Screw	M4x.7x30	2
29	PJN-S04	Eccentric Cam		2
30	TS-1523011	Set Screw	M6x1.0x6	2
31	HG010911	Spring Pin	4x20	1
32	PG010033	Spring		1
33	MHD-S03	Shaft		1
34	5EA-E06A	Flat Head Screw	M6x1.0x12	4
35	PJ100001	Door		1
36	TS-0561031	Lock Nut	3/8-16NC	4
37	PJE-S05	Wheel		4
38	5CA-H16B	Hex Cap Bolt	3/8-16NCx2 1/2	4
39	PG-M02	JET Label		1
40	TS-1503031	Hex Socket Cap Screw	M6x1.0x12	1
41	PJN-S02	Foot Brake		1
42	TS-1550071	Washer	M10	1
43	TS-2342101	Lock Nut	M10x1.5	1
44	TS-1550041	Flat Washer	M6	4
45	HS020440	Hex Socket Cap Screw'	M6x70	4
	708361	Dust Chute Assembly		1
	MHD-S17	Hardware Bag (not shown)		1
	MHA-X06	Brass Bar (not shown)		1
	MGA-B14A	Feed Roller Adjustment Wrench 17/32 mm (not shown)		1
	MGA-B14D	Knife Setting Gauge (not shown)		1
	MGA-B14F	Molding Cutter Gauge (not shown)		1
	MHA-X07	T-Handle Hex Wrench (not shown)	4mm	1

* included in Hardware Bag